

HX480AL HX520AL

CRAWLER EXCAVATOR



SERIES / HX480AL HX520AL

Gross Power
298 kW (400 hp) at 2100 rpm

Bucket Capacity
1.38 m³ ~ 3.2 m³

Net Power
295 kW (395 hp) at 2100 rpm

Operating Weight
50690 kg & 52048 kg

READY TO CHANGE YOUR WORLD

The HX480A L and HX520A L Crawler Excavators are part of Hyundai's brand new A-series: a fresh generation of construction equipment that complies with the European Stage V emission levels. But it goes much further than that! While fulfilling regulatory demands, Hyundai aimed for a ground-breaking level of customer satisfaction with maximum performance and productivity, better safety, more convenience and improved uptime management.

From their robust exterior design to their performance-enhancing smart technologies, these mighty machines open up a world of new possibilities where tiny efforts move mountains. It's time to experience the Hyundai Effect!



THE BEST PRODUCTIVITY AND FUEL EFFICIENCY

The HX480A L and HX520A L are powered by a robust Stage V-certified Cummins X12 engine with an innovative integrated after-treatment system that reduces both emissions and maintenance requirements. It delivers all the power you need to handle demanding jobs, along with better fuel efficiency and fast levelling and truck loading times.

A range of smart technologies enable precise management of the engine output and pump flow rate. The new EPIC (Electric Pump Independent Control) hydraulic system improves efficiency through automated control of the individual hydraulic pumps. A Lifting work mode is included to improve fine control by boosting RPM, activating power boost and controlling pump flow. Additional features optimise operation and monitoring to enhance productivity every single day.

The technology to improve efficiency

Engine

Like all A-Series machines, the HX480A L and HX520A L feature our all-in-one exhaust aftertreatment system, which cuts emissions and operating costs while enhancing reliability and simplifying maintenance.



4% LEVELLING
6% LOADING
(compared to HX Series)

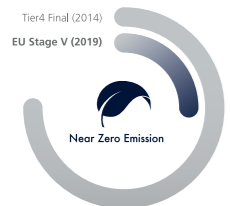

Automatic engine shutdown ▲

This option ensures that the engine shuts down automatically when the machine is idling to cut fuel consumption and prevent unnecessary emissions.

Fuel rate information

Average or recent fuel consumption can be displayed to guide you towards more economical operation.

Eco Report

The Eco Report feature helps you to develop efficient working habits by displaying real-time information about machine performance.

Eco Gauge ▼

The gauge level adjusts according to the engine workload, while different colours provide an instant view of fuel savings during operation.



EPIC hydraulic system ▲

The HX A-Series features an improved IPC (Intelligent Power Control) system that optimises the pump flow rate and power at various working conditions through individual pump control. EPIC improves fuel efficiency while helping to reduce losses in hydraulic flow and maximise production capacity.



NEW EXTERIOR DESIGN FOR ROBUSTNESS AND SAFETY

You need to know that the investment you make today will help to sustain your business over the long term. That's why we prioritised reliability throughout the development of the HX480A L and HX520A L, from design and manufacturing to quality control. The upper and lower frame structures are reinforced for high load work, while the attachments have been rigorously tested for the roughest conditions. The overall aim is to minimise downtime and repairs so that you can stay on schedule, avoid unexpected costs and protect your profits.



Tougher from the ground up

Frame structures and attachments ▶

The upper and lower frame structures have been reinforced and rigorously tested (both on the road and through virtual simulation) to ensure that they exceed on-site demands for durability. The wear resistance of the bucket has been improved through the use of new material.



Durable cooling module ▶

HX A-Series machines are enhanced with a durable cooling module that has been stringently tested and has demonstrated the highest productivity in tough working environments. An automatically reversible fan is installed to protect the radiators from flying debris.



Side protectors ▼

These excavators can be equipped with side bumpers as an option to absorb any impact on the exterior frame and protect your equipment.



Removable counterweight ▶

Counterweights with different tonnages are available to allow you to tailor your machine for any application. For easier transport, hydraulically removable counterweights are available as an option.



EASY CONTROL AND COMFORTABLE OPERATION

Many electronic functions are concentrated in the most convenient spot for operators to improve work efficiency. The highly-advanced infotainment system, a product of Hyundai's intensive information technology development, enables both productivity and comfort while working! The HX A-Series really is designed with the operator in mind.

Ergonomic for efficient operation

Intelligent & wide cluster ▶

The 8" capacitive-type display is similar to a smartphone to deliver excellent legibility. The centralised switches on the display allow convenient checking of the Adblue/DEF level and temperature outside the cabin.



One pedal to travel straight ▶

One pedal for straight travel is available for customers' convenience when long distance travelling or a combination of attachment work with travelling is necessary.



Proportional auxiliary hydraulic system ▶

A proportional control switch with better speed control provides operators with added convenience whenever they do time-consuming work. This function can also be switched to control by foot pedal, by changing the setting in the cluster menu.



Jog Dial Module ▶

The accelerator, remote air conditioner controller and instrument cluster can be operated using the convenient jog shuttle-type controller.



Functionality at your fingertips

Boom/Arm speed

Boom-up speed compared to swing speed can be adjusted by activating/deactivating the boom priority function. Arm-in speed can be also tuned by activating/deactivating the arm regeneration function.

Work mode memory

The operator can save machine settings, so that they are applied when starting the machine.

OME (Owner Menu Editing)

The machine owner can restrict operator access to the set of functions via the menu as well as locking or unlocking it. A password is then needed to access the functions.

Fine (cushion/free) swing control

This option enables smooth movement at the start and stop of swing operation (cushion swing). In addition, it reduces the shaking of the weight when lifting operation (free swing).

The HX A-Series is designed with the operator in mind. Many electronic functions are concentrated in the most convenient spot for operators to improve work efficiency.



Pilot pressure operated joysticks and pedals with detachable lever provide almost effortless operation.

13%
INCREASE IN CABIN SPACE

THE ULTIMATE SAFE ENVIRONMENT

Small details can make a huge difference when it comes to safety and security. The HX480A L and HX520A L offer all-round protection for you, your workmates and your machinery. The cabin is designed to provide maximum visibility, with the option of Advanced Around View Monitoring (AAVM) for an even broader field of vision. By helping to ensure an accident-free worksite, these crawler excavators contribute to the peace of mind and productivity that form part of the Hyundai Effect.



Built for safer operation

Electronic swing brake

An electronic valve and control system has been added to improve safety and utilisation. The opening and closing time of the swing brake valve is controlled according to the sensing and control system.



Seat belt warning alarm

If the seatbelt is not buckled when the ignition key is turned, an alarm is triggered in intervals along with a continuous visual alert. This emphasises our priority for operator safety.

Side camera ▲

In addition to the standard rear view camera, there is an optional right hand side camera for giving the operator improved visibility.

Visibility and handle improvement ▲

Visibility through the cabin door has been improved as has the handle design, to offer greater convenience when getting in and out of the cabin.

Advanced Around View Monitoring (AAVM) ▶

The AAVM camera system gives you a 360° overview of your immediate working environment. It also includes Intelligent Moving Object Detection (IMOD) technology that senses and warns you when people or objects come within five metres of the machine.



Activate Auto Safety Lock

The Auto Safety Lock prevents unintended operation due to the excavator not being controlled solely by the RCV lever.



SERVICEABILITY AND TELEMATICS

Our A-Series excavators are designed with quick, low-effort servicing in mind. Every component and material has been optimised to ensure a long, trouble-free life. Hyundai's innovative Hi MATE telematics system enables full monitoring of machine activity and performance. Maximum connectivity is integrated to help owners create a smart construction site and protect profitability as their business grows.

Less maintenance. More uptime

Improved routine maintenance

Easy access for maintenance means regular checks get done faster, giving you more uptime and reducing operating costs. Ground level access to filters, lube fittings and master switches make servicing more convenient.

2 x longer lasting filter (1000 hr)

Service intervals have increased by 100% from 500hrs to 1000hrs when using CK-4 engine oil on the following items, engine oil, pre-filter, engine oil filter and fuel filter.

100%
IMPROVEMENT IN SERVICE INTERVAL



Hi MATE

It's convenient, easy and valuable. Hi MATE, Hyundai's remote management system, utilises GPS-satellite technology to provide customers with the highest level of service and product support available.

Increase productivity

By providing information such as service hours, idle time and fuel consumption, Hi MATE saves you money and improves productivity. Service alerts enable better maintenance planning.

ECD

(Engine Connected Diagnostics)

ECD provides troubleshooting information as well as tailored servicing. Service technicians are supported with remote diagnostics allowing them to achieve quick resolution rate

Monitor your machines

Hi MATE's real-time location information allows convenient monitoring of your equipment via the Hi MATE website or mobile app.

Mobile fleet app

Our Mobile Fleet app provides all the information you need to run your fleet efficiently and economically.

Improve Security

Protect your equipment from theft or unauthorised usage. Hi MATE's geofencing alerts notify you automatically when a machine leaves a predetermined zone.



HCE-DT Air connects you and your equipment wirelessly via smartphone and laptop right on site.

Keeping you covered

Hyundai genuine parts and accessories are designed to keep your machine running at optimum performance, providing increased uptime, comfort and productivity. Our 13000m² European Parts Warehouse guarantees 24-hour delivery across our dealer network.

Hyundai Standard and Extended Warranty Programmes are also available, providing peace of mind and giving you full control over your operating costs.



TAKE THE TOUR!

Productivity & Efficiency

- High-performing Stage V engine
- Eco Report
- Lifting mode
- EPIC hydraulic system
- Fuel Rate Information
- Eco Gauge
- Automatic engine shutdown

Safety

- Auto safety lock
- Electronic swing brake
- AAVM camera system
- Seat belt warning alarm
- Cabin suspension mount

Serviceability & Connectivity

- Hi MATE
 - ECD (Engine Connected Diagnostics)
 - Mobile fleet app
- HCE-DT Air
- Maintenance-free DPF system

A

SERIES HX480A L HX520A L

Durability

- Side protector
- ROPS / FOG / FOPS certified cabin
- Reinforced upper and lower structure
- Reinforced attachments
- Durable cooling module
- Reinforced pins, bushings and polymer shims
- Wear-resistant cover plate

Ease of Use

- Improved visibility and door handle design
- Key On Init work mode
- Straight travel pedal
- Proportional auxiliary hydraulic system
- Fine (cushion/free) swing control
- Integrated audio system
- 8" touchscreen monitor
- Jog shuttle-type rotary dial
- Owner Menu Editing (OME)



HX480A L / HX520A L SPECIFICATIONS

SPECIFICATIONS	HX480A L	HX520A L
ENGINE		
Maker / Model	CUMMINS / X12	
Type	6 cylinder, water cooled, 4-cycle, turbocharged charge air cooled, direct injection, electronic controlled diesel engine.	
Gross Power	298 kW (400 hp) at 2100 rpm	
Net Power	295 kW (395 hp) at 2100 rpm	
Max. Power	300 kW (402 hp) at 1800 rpm	
Peak Torque	1,898 N m at 1400 rpm	
Displacement	11.8 l	
Operating Altitude (w/o derate)	2000 m	
HYDRAULIC SYSTEM		
MAIN PUMP		
Type	Variable displacement axis piston pumps	
Max. Flow	2 × 394 lpm 1 × 23.9 lpm	
Sub-Pump For Pilot Circuit	Gear pump	
HYDRAULIC MOTORS		
Travel	Two speed axial pistons motor with brake valve and parking brake	
Swing	Axial piston motor with automatic brake	
RELIEF VALVE SETTING		
Implement Circuits	330 kgf/cm ²	
Travel	360 kgf/cm ²	
Power Boost (Boom, Arm, Bucket)	360 kgf/cm ²	
Swing Circuit	285 kgf/cm ²	
Pilot Circuit	40 kgf/cm ²	
Service Valve	Installed	
HYDRAULIC CYLINDERS		
No. of Cylinder Bore X Stroke	Boom Ø170 × 1580 mm	
	Arm Ø190 × 1820 mm	
	Bucket Ø160 × 1370 mm	Bucket Ø170 × 1370 mm
Cross-sensing and fuel saving pump system.		
DRIVES & BRAKES		
Drive Method	Fully hydrostatic type	
Drive Motor	Axial piston motor, in-shoe design	
Reduction System	Planetary reduction gear	
Max. Drawbar Pull	34100 kgf	
Max. Travel Speed (High / Low)	3.3 km/hr / 5.3 km/hr	
Gradeability	35° (70%)	
Parking Brake	Multi wet disc	
CONTROL		
Pilot pressure operated joysticks and pedals with detachable lever provide almost effortless and fatigueless operation.		
Pilot Control	Two joysticks with one safety lever (LH) : Swing and arm, (RH) : Boom and bucket (ISO)	
Traveling and Steering	Two levers with pedals	
Engine Throttle	Electric, dial type	
SWING SYSTEM		
Swing Motor	Axial piston motor	
Swing Reduction	Planetary gear reduction	
Swing Bearing Lubrication	Grease-bathed	
Swing Brake	Multi wet disc	
Swing Speed	9.0 rpm	

SPECIFICATIONS	HX480A L	HX520A L			
COOLANT & LUBRICANT CAPACITY					
		liter			
Fuel Tank		600			
Engine Coolant		43			
Engine Oil		34			
Swing Device		7			
Final Drive (Each)		13			
Hydraulic System (Including Tank)		499			
Hydraulic Tank		275			
Def/Adblue®		70			
UNDERCARRIAGE					
The X-leg type center frame is integrally welded with reinforced box-section track frames. The undercarriage includes lubricated rollers, idlers, track adjusters with shock absorbing springs and sprockets, and a track chain with double or triple grouser shoes.					
Center Frame	X - Leg Type				
Track Frame	Pentagonal Box Ty				
No. of Shoes on Each Side	53 EA				
No. of Carrier Rollers on Each Side	2 EA				
No. of Track Rollers on Each Side	9 EA				
No. of Rail Guards on Each Side	2 EA				
OPERATING WEIGHT (APPROXIMATE)					
Operating weight, including 7060 mm boom, 3380 mm arm, SAE heaped 2.2 m ³ bucket, lubricant, coolant, full fuel tank, full hydraulic tank, and all standard equipments.					
Shoes	Width	Operating Weight	Ground Pressure	Operating Weight	Ground Pressure
Type	mm	kg	kgf/cm ²	kg	kgf/cm ²
Triple Grouser	600	49997	0.87	52001	0.90
	700	50540	0.75	52521	0.78
	800	51083	0.66	53051	0.69
	900	51626	0.6	53559	0.62
Double Grouser	600	50029	0.87	52033	0.90
	700	50572	0.75	52563	0.78
NOISE					
Operator Sound Pressure Level (ISO 6396:2008)	70 dB(A)				
Exterior Sound Power Level (ISO 6395:2008)	107 dB(A)				
AIR CONDITIONING SYSTEM					
The air conditioning system contains fluorinated greenhouse gas refrigerant R134a (Global Warming Potential = 1430). The system contains 0.80 kg of refrigerant representing a CO ₂ equivalent of 1.14 metric tonnes.					

HX480A L / HX520A L DIMENSIONS

HX480A L DIMENSIONS

6.55 m, 7.06 m, 9.0 m boom and 2.55 m, 2.9 m, 3.38 m, 4.0 m, 6.0 m arm

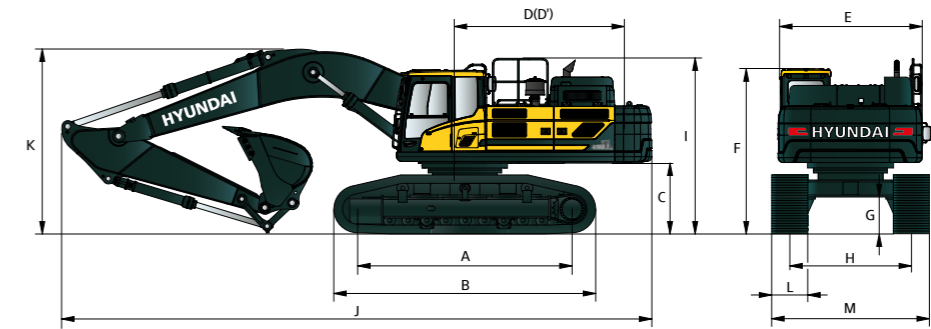

Unit : mm

A	Tumbler Distance	4470
B	Overall Length of Crawler	5416
*C	Ground Clearance of Counter Weight	1295
D	Tail Swing Radius	3800
D'	Rear-end Length	3745
E	Overall Width of Upper Structure	2980
*F	Overall Height of Cab	3220
G	Min. Ground Clearance	565
H	Track gauge	2740
*I	*Overall Height of Guardrail	3450

	Boom Length	6550	7060	9000			
	Arm Length	2550	2550	2900	3380	4000	6000
J	Overall Length	11650	12010	12110	12040	12170	14010
*K	Overall Height of Boom	3950	4110	3920	3790	3900	3990

L	Track Shoe Width	600	700	800	900
M	Overall Width	3340	3440	3540	3640

HX520A L DIMENSIONS

6.55 m, 7.06 m, 9.0 m boom and 2.55 m, 2.9 m, 3.38 m, 4.0 m, 6.0 m arm

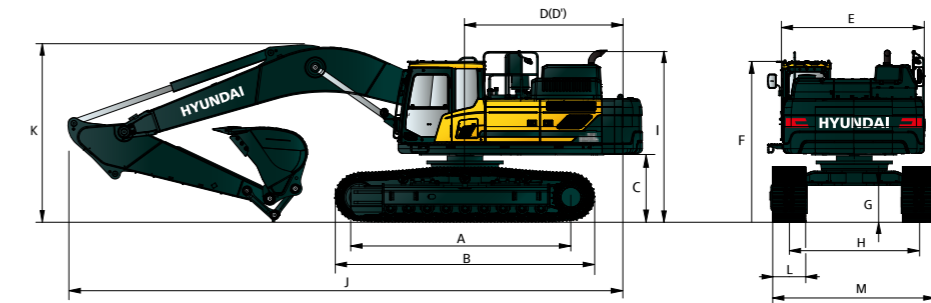

Unit : mm

A	Tumbler Distance	4470	
B	Overall Length of Crawler	5416	
*C	Ground Clearance of Counter Weight	1445	
D	Tail Swing Radius	3800	
D'	Rear-End Length	3745	
E	Overall Width of Upper Structure	2980	
*F	Overall Height of Cab	3365	
G	Min. Ground Clearance	770	
H	Track gauge	Extended	2940
		Retracted	2380
*I	Overall Height Guardrail	3595	

	Boom Length	6550	7060	9000			
	Arm Length	2550	2550	2900	3380	4000	6000
J	Overall Length	12260	12260	12290	12040	12160	13980
*K	Overall Height of Boom	3980	4110	4065	3790	3900	3960

L	Track Shoe Width	600	700	800	900	
M	Overall gauge	Extended	3540	3640	3740	3840
		Retracted	2980	3080	3180	3280

* This figure includes the size of grousers.

HX480A L / HX520A L WORKING RANGE

HX480A L WORKING RANGE

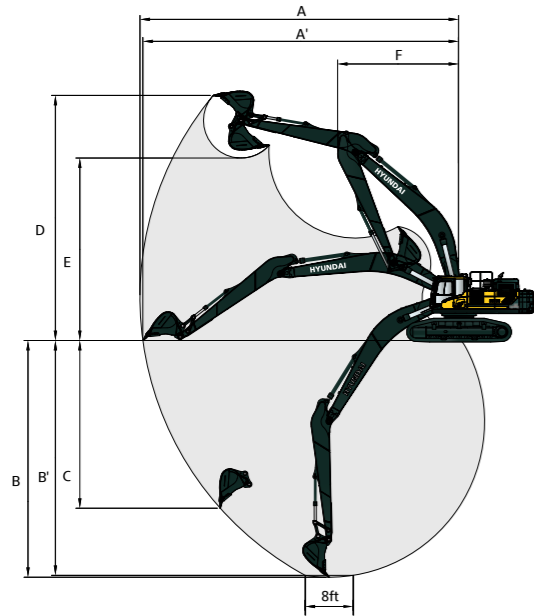

Unit : mm

Boom Length	6550	7060				9000
Arm Length	2550	2550	2900	3380	4000	6000
A Max. Digging Reach	10860	11410	11620	12040	12600	16180
A' Max. Digging Reach on Ground	10640	11200	11410	11840	12410	16030
B Max. Digging Depth	6570	6930	7280	7760	8380	12020
B' Max. Digging Depth (8' Level)	6400	6760	7120	7620	8250	11920
C Max. Vertical Wall Digging Depth	5550	5720	5800	5920	6470	8510
D Max. Digging Height	10580	11110	10930	11030	11260	12610
E Max. Dumping Height	7070	7570	7490	7640	7870	9410
F Min. Swing Radius	4550	4780	4890	4770	4630	6040

HX520A L WORKING RANGE

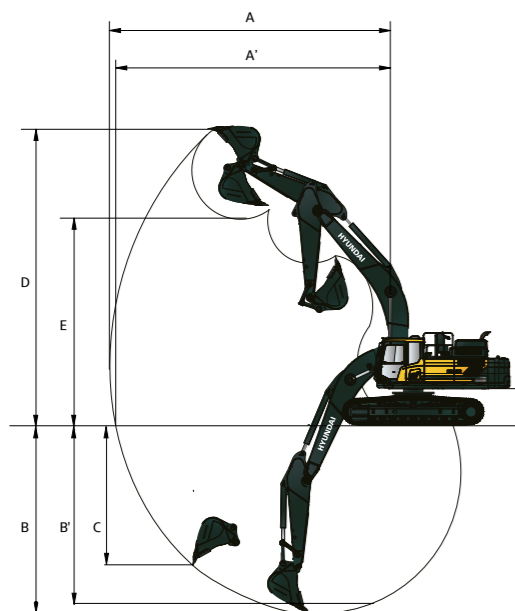

Unit : mm

Boom Length	6550	7060				9000
Arm Length	2550	2550	2900	3380	4000	6000
A Max. digging reach	10860	11410	11620	12040	12600	16180
A' Max. digging reach on ground	10610	11170	11380	11810	12380	16010
B Max. digging depth	6420	6780	7130	7610	8230	11870
B' Max. digging depth (8' level)	6250	6610	6980	7470	8110	11770
C Max. vertical wall digging depth	5400	5570	5650	5770	6320	8360
D Max. digging height	10730	10960	11080	11180	11410	12760
E Max. dumping height	7220	7720	7630	7780	8020	9560
F Min. swing radius	4390	4780	4890	4770	4630	6040

HX480A L LIFTING CAPACITY

Rating over-front Rating over-side or 360 degrees

HX480A L

6.55 m boom, 2.55 m arm equipped with 600 mm triple grouser shoe (without bucket).

Lift-point height m	Lift-point radius										At max. Reach		
	3.0 m		4.5 m		6.0 m		7.5 m		9.0 m		Capacity	Reach	
9.0 m											*13880	*13880	5.79
7.5 m					*13190	*13190					*12600	11260	7.22
6.0 m					*13980	*13980	*12410	10490			*12070	9160	8.12
4.5 m			*20370	*20370	*15430	14260	*12960	10190			*11830	8090	8.67
3.0 m					*16960	13480	*13650	9810			*11730	7550	8.94
1.5 m					*17890	12900	*14120	9480			*11690	7410	8.94
0.0 m			*21030	19190	*17850	12600	*14030	9280			*11620	7630	8.69
-1.5 m	kg	*15060	*15060	*21280	19290	*16720	12550	*13030	9260		*11390	8330	8.15
-3.0 m	kg	*20530	*20530	*17830	*17830	*14160	12740				*10720	9890	7.26
-4.5 m	kg												

7.06 m boom, 2.55 m arm equipped with 600 mm triple grouser shoe (without bucket).

Lift-point height m	Lift-point radius										At max. Reach		
	3.0 m		4.5 m		6.0 m		7.5 m		9.0 m		Capacity	Reach	
9.0 m											*12320	*12320	6.55
7.5 m							*11710	10990			*11350	10150	7.84
6.0 m					*13770	*13770	*11980	10810			*11020	8490	8.69
4.5 m					*15410	14460	*12710	10440	*11200	7900	*11070	7600	9.21
3.0 m					*17010	13660	*13500	10030	*11470	7710	*10990	7140	9.47
1.5 m					*17890	13110	*14050	9690	*11630	7540	*10970	7010	9.48
0.0 m					*17820	12840	*14080	9480	*11380	7440	*10930	7180	9.25
-1.5 m	kg		*20840	19760	*16830	12810	*13390	9430			*10780	7740	8.75
-3.0 m	kg	*19580	*19,580	*18070	*18070	*14800	12960	*11510	9570		*10330	8920	7.94
-4.5 m	kg		*13620	*13620	*10950	*10950					*9050	*9050	6.71

7.06 m boom, 2.90 m arm equipped with 600 mm triple grouser shoe (without bucket).

Lift-point height m	Lift-point radius										At max. Reach		
	3.0 m		4.5 m		6.0 m		7.5 m		9.0 m		Capacity	Reach	
9.0 m											*11510	*11510	6.97
7.5 m							*10980	10870			*10810	9310	8.19
6.0 m					*13030	*13030	*11370	10620			*10500	7840	8.99
4.5 m			*19780	*19780	*14660	14220	*12140	10200	*10690	7680	*10370	7030	9.49
3.0 m					*16310	13340	*12980	9740	*11040	7460	*10340	6600	9.74
1.5 m					*17350	12700	*13600	9360	*11280	7240	*10360	6460	9.74
0.0 m			*14480	*14480	*17470	12370	*13750	9110	*11190	7110	*10380	6610	9.51
-1.5 m	kg		*21210	18970	*16700	12290	*13230	9030	*10370	7110	*10320	7090	9.02
-3.0 m	kg	*21630	*21630	*18580	*18580	*14930	12420	*11720	9130		*10040	8120	8.23
-4.5 m	kg			*14450	*14450	*11610	*11610				*9130	*9130	7.04

- Lifting capacity is based on ISO 10567.
- Lifting capacity of the HX Series does not exceed 75% of tipping load with the machine on firm, level ground or 87% of full hydraulic capacity.
- The Lift-point is bucket pivot mounting pin on the arm (without bucket mass).
- (*) indicates load limited by hydraulic capacity.
- Caution: please be aware of the local regulations and instructions for lifting operations.

HX480A L

LIFTING CAPACITY

Rating over-front Rating over-side or 360 degrees

HX480A L

7.06 m boom, 3.38 m arm equipped with 600 mm triple grouser shoe (without bucket).

Lift-point height m	Lift-point radius										At max. Reach			
	3.0 m		4.5 m		6.0 m		7.5 m		9.0 m		Capacity	Reach		
											kg	m		
9.0 m	kg										*9450	*9450	7.51	
7.5 m	kg										*8950	8610	8.65	
6.0 m	kg										*10850	10770	9.41	
4.5 m	kg			*18480	*18480	*14010	*14010	*11700	10340	*10330	7770	*8960	6630	9.89
3.0 m	kg					*15810	13600	*12650	9870	*10790	7520	*9350	6240	10.12
1.5 m	kg					*17100	12880	*13410	9450	*11150	7280	*9890	6110	10.13
0.0 m	kg			*17130	*17130	*17540	12460	*13740	9150	*11240	7110	*9970	6220	9.91
-1.5 m	kg	*12220	*12220	*22260	18940	*17080	12310	*13470	9020	*10780	7050	*10000	6620	9.44
-3.0 m	kg	*20690	*20690	*19920	19140	*15660	12370	*12340	9050			*9900	7470	8.69
-4.5 m	kg	*19790	*19790	*16250	*16250	*12920	12640	*9580	9330			*9390	9220	7.57

7.06 m boom, 4.00 m arm equipped with 600 mm triple grouser shoe (without bucket).

Lift-point height m	Lift-point radius										At max. Reach						
	1.5 m		3.0 m		4.5 m		6.0 m		7.5 m		9.0 m		10.5 m		Capacity	Reach	
															kg	m	
9.0 m	kg														*7340	*7340	8.24
7.5 m	kg														*7010	*7010	9.29
6.0 m	kg														*6930	6760	10.01
4.5 m	kg														*7030	6160	10.46
3.0 m	kg														*7320	5820	10.68
1.5 m	kg														*7820	5700	10.68
0.0 m	kg														*8600	5780	10.47
-1.5 m	kg			*12230	*12230	*23290	18980	*17450	12390	*13710	9070	*11110	7060		*9540	6100	10.03
-3.0 m	kg	*14130	*14130	*18540	*18540	*21430	19080	*16470	12360	*12980	9040	*10210	7080		*9570	6760	9.33
-4.5 m	kg			*23840	*23840	*18340	*18340	*14340	12540	*11120	9190				*9360	8060	8.30
-6.0 m	kg					*13350	*13350	*10290	*10290						*8450	*8450	6.78

9.00 m boom, 6.00 m arm equipped with 600 mm triple grouser shoe (without bucket).

Lift-point height m	Lift-point radius														At max. Reach							
	1.5 m		3.0 m		4.5 m		6.0 m		7.5 m		9.0 m		10.5 m		12.0 m		13.5 m		Capacity	Reach		
																			kg	m		
10.5 m	kg																		*4060	*4060	11.51	
9.0 m	kg																		*3950	*3950	12.46	
7.5 m	kg																		*3940	*3940	13.17	
6.0 m	kg																		*6270	*6270	13.69	
4.5 m	kg																		*6270	*6270	13.69	
3.0 m	kg																		*6270	*6270	13.69	
1.5 m	kg																		*6270	*6270	13.69	
0.0 m	kg																		*6270	*6270	13.69	
-1.5 m	kg	*4710	*4710	*6130	*6130	*10400	*10400	*15390	10970	*11920	8030	*9650	6210	*8060	4950	*6890	4020	*5910	3310	*5510	3230	13.70
-3.0 m	kg	*7100	*7100	*8690	*8690	*12720	*12720	*15140	10770	*11890	7820	*9660	6030	*8040	4810	*6790	3930		*5880	3400	13.20	
-4.5 m	kg	*9580	*9580	*11500	*11500	*15760	*15760	*14400	10760	*11470	7750	*9360	5960	*7750	4770	*6400	3930		*5950	3710	12.50	
-6.0 m	kg	*12310	*12310	*14730	*14730	*16720	*16720	*13140	10920	*10590	7830	*8650	6010	*7060	4830				*5980	4240	11.55	
-7.5 m	kg			*18050	*18050	*13990	*13990	*11240	11230	*9120	8040	*7360	6190						*5870	5160	10.31	
-9.0 m	kg					*10190	*10190	*8390	*8390	*6720	*6720								*5410	*5410	8.62	

- Lifting capacity is based on ISO 10567.
- Lifting capacity of the HX Series does not exceed 75% of tipping load with the machine on firm, level ground or 87% of full hydraulic capacity.
- The Lift-point is bucket pivot mounting pin on the arm (without bucket mass).
- (*) indicates load limited by hydraulic capacity.
- Caution: please be aware of the local regulations and instructions for lifting operations.

HX520A L

LIFTING CAPACITY

Rating over-front Rating over-side or 360 degrees

HX520A L

6.55 m boom, 2.55 m arm equipped with 0.92 m³ (SAE heaped) bucket.

Lift-point height m	Lift-point radius										At max. Reach											
	3.0 m		4.5 m		6.0 m		7.5 m		9.0 m		Capacity	Reach										
											kg	m										
9.0 m	kg												*13740	*13740	5.92							
7.5 m	kg												*12550	*12550	7.29							
6.0 m	kg												*12050	10550	8.17							
4.5 m	kg												*11820	9390	8.70							
3.0 m	kg												*11730	8840	8.94							
1.5 m	kg												*11690	8720	8.93							
0.0 m	kg												*11610	9020	8.66							
-1.5 m	kg	*16090	*16090	*21090	*21090	*16590	14850	*12900	10920				*11370	9900	8.10							
-3.0 m	kg	*20140	*20140	*17510	*17510	*13900	*13900						*10640	*10640	7.18							
-4.5 m	kg																					

7.06 m boom, 2.55 m arm equipped with 0.92 m³ (SAE heaped) bucket.

Lift-point height m	Lift-point radius										At max. Reach				
	3.0 m		4.5 m		6.0 m		7.5 m		9.0 m		Capacity	Reach			
											kg	m			
9.0 m	kg												*12180	*12180	6.70
7.5 m	kg												*11290	*11290	7.94
6.0 m	kg												*11000	9650	8.75
4.5 m	kg												*11040	8710	9.25
3.0 m	kg												*10970	8240	9.48
1.5 m	kg												*10950	8140	9.47
0.0 m	kg												*10900	8380	9.21
-1.5 m	kg												*10730	9080	8.69
-3.0 m	kg	*19250	*19250	*17710	*17710	*14510	*14510	*11200	11150				*10240	*10240	7.85
-4.5 m	kg												*8820	*8820	6.56

7.06 m boom, 2.90 m arm equipped with 0.92 m³ (SAE heaped) bucket.

Lift-point height m	Lift-point radius										At max. Reach				
	3.0 m		4.5 m		6.0 m		7.5 m		9.0 m		Capacity	Reach			
											kg	m			
9.0 m	kg												*11430	*11430	7.08
7.5 m	kg												*10780	10640	8.26
6.0 m	kg												*10480	9060	9.04
4.5 m	kg												*10370	8190	9.52
3.0 m	kg												*10340	7750	9.74
1.5 m	kg												*10370	7640	9.73
0.0 m	kg												*10380	7840	9.48
-1.5 m	kg												*10310	8440	8.98
-3.0 m	kg	*21360	*21360	*18340	*18340	*14760	14730	*11550	10810				*10000	9710	8.16
-4.5 m	kg												*9020	*9020	6.93

- Lifting capacity is based on ISO 10567.
- Lifting capacity of the HX Series does not exceed 75% of tipping load with the machine on firm, level ground or 87% of full hydraulic capacity.
- The Lift-point is bucket pivot mounting pin on the arm (without bucket mass).
- (*) indicates load limited by hydraulic capacity.
- Caution: please be aware of the local regulations and instructions for lifting operations.

HX480A L / HX520A L DIGGING FORCE

DIGGING FORCE									
Boom	Length	mm	6550	7060				9000	Remark
	Weight	kg	4340	4370				5130	
Arm	Length	mm	2550	2550	2900	3380	4000	6000	Power Boost
	Weight	kg	2350	2350	2590	2630	2720	3290	
Bucket Digging Force	SAE	kN	212.8 [231.0]	212.8 [231.0]	212.8 [231.0]	212.8 [231.0]	212.8 [231.0]	212.8 [231.0]	[:] Power Boost
		kgf	21700 [23560]	21700 [23560]	21700 [23560]	21700 [23560]	21700 [23560]	21700 [23560]	
	ISO	kN	247.1 [268.3]	247.1 [268.3]	247.1 [268.3]	247.1 [268.3]	247.1 [268.3]	247.1 [268.3]	
		kgf	25200 [27360]	25200 [27360]	25200 [27360]	25200 [27360]	25200 [27360]	25200 [27360]	
Arm Crowd Force	SAE	kN	235.4 [255.6]	235.4 [255.6]	218.7 [237.4]	198.1 [215.1]	173.6 [188.5]	127.5	
		kgf	24000 [26060]	24000 [26060]	22300 [24210]	20200 [21930]	17700 [19220]	13000	
	ISO	kN	246.1 [267.2]	246.1 [267.2]	227.5 [247.0]	205.0 [222.5]	179.5 [194.9]	130.4	
		kgf	25100 [27250]	25100 [27250]	23200 [25190]	20900 [22690]	18300 [19870]	13300	

Note: Boom weight includes arm cylinder, piping, and pin
Arm weight includes bucket cylinder, linkage, and pin

HX480A L / HX520A L STANDARD/OPTIONAL EQUIPMENT

ENGINE	HX480A L HX520A L	
Cummins X12	●	●
HYDRAULIC SYSTEM	HX480A L HX520A L	
EPIC HYDRAULIC SYSTEM		
3-Power Mode, 2-Work Mode, User Mode	●	●
Variable Power Control	●	●
EPIC (Electric Pump Flow Control)	●	●
Attachment Mode Flow Control	●	●
Engine Auto Idle	●	●
Engine Auto Shutdown Control	●	●
Hyundai Bio Hydraulic Oil (HBHO)	●	●
CAB & INTERIOR	HX480A L HX520A L	
ISO Standard cabin		
Cabin Lights (LED)	●	●
Cabin Front Window Rain Guard	●	●
Cabin Roof-Steel Cover	○	○
Rise-Up Type Windshield Wiper	●	●
Radio / USB Player	●	●
Handsfree Mobile Phone System with USB	●	●
12 V Power Outlet (24 V DC to 12 V DC Converter)	●	●
Electric Horn	●	●
All-Weather Steel Cab with 360° Visibility	●	●
Safety glass - Tempered Glass with Front Laminated Glass	●	●
Sliding Fold-In Front Window	●	●
Sliding Side Window (LH)	●	●
Air compressor with Hand Gun	○	○
Lockable Door	●	●
Hot & Cool Box	●	●
Storage Compartment	●	●
Smoker Kit	○	○
Transparent Cabin Roof-Cover	●	●
Sun Visor	●	●
Door and Cab Locks, One Key	●	●
Pilot-Operated Slidable Joystick	●	●
Console Box Height Adjust System	●	●
Automatic climate control		
Air Conditioner & Heater	●	●
Defroster	●	●
Starting Aid (Air Grid Heater) for Cold Weather	●	●
Centralized monitoring		
8" LCD Display	●	●
Engine Speed or Trip Meter / Accel	●	●
Engine Coolant Temperature Gauge	●	●
Max Power	●	●
Low Speed / High Speed	●	●
Auto Idle	●	●
Overload warning with alarm	●	●
Check Engine	●	●
Air Cleaner Clogging	●	●
Indicators	●	●
Eco Gauges	●	●
Fuel Level Gauge	●	●
Hyd. Oil Temperature Gauge	●	●
Fuel Warmer	●	●
Warnings	●	●
Communication Error	●	●
Low Battery	●	●
Clock	●	●
Seat		
Mechanical Suspension with Heater	●	●
Adjustable Air Suspension without Heater	○	○
Adjustable Air Suspension with Heater	○	○
CABIN FOG (ISO 10262) LEVEL 2		
FOG (Falling Object Guard)	○	○
Front & Top Guard	○	○
Top Guard	○	○
CABIN ROPS (ISO 12117-2)		
ROPS (Roll Over Protective Structures)	●	●

SAFETY	HX480A L HX520A L	
Battery Master Switch	●	●
Rearview Camera	●	●
AAVM (Advanced Around View Monitoring)	○	○
Six Front Working Lights (4 Boom Mounted, 2 Front Frame Mounted)	●	●
Travel Alarm	●	●
Rear Work Lamp (LED)	●	●
Beacon Lamp	○	○
Automatic Swing Brake	●	●
Boom Holding System	●	●
Arm Holding System	●	●
Safety Lock Valve for Boom Cylinder with Overload Warning Device	●	●
Safety Lock Valve for Arm Cylinder	●	●
Swing Lock System	○	○
Two Outside Rearview Mirrors	●	○
Three Outside Rearview Mirrors	○	●
ATTACHMENT	HX480A L HX520A L	
Booms		
6.55 m	○	○
7.06 m	●	●
9.00 m	○	○
Arms		
2.55 m	○	○
2.90 m	○	○
3.38 m	●	●
4.00 m	○	○
6.00 m	○	○
UNDERCARRIAGE	HX480A L HX520A L	
Lower Frame Under Cover (Additional)	○	○
Lower Frame Under Cover (Normal)	●	●
Track shoes		
Triple Grousers Shoes (600 mm)	●	●
Triple Grousers Shoe (700 mm)	○	○
Triple Grousers Shoe (800 mm)	○	○
Triple Grousers Shoe (900 mm)	○	○
Double Grousers Shoe (600 mm)	○	○
Double Grousers Shoe (700 mm)	○	○
Track Rail Guard	●	●
Full Track Rail Guard	○	○
3-piece Type Track Guard	○	○
OTHERS	HX480A L HX520A L	
Removable Clean-Out Dust Net for Cooler	●	●
Removable Washer Tank	●	●
Fuel Pre-Filter	●	●
Fuel Warmer	●	●
Self-Diagnostics System	●	●
Hi MATE (Remote Management System)	○	○
Batteries (2 × 12 V × 200 AH)	●	●
Fuel Filler Pump (50 lpm)	○	○
Single-Acting Piping Kit (Breaker, etc.)	○	○
Double-Acting Piping Kit (Clamshell, etc.)	●	●
Rotating Piping Kit	○	○
Quick Coupler Piping	○	○
Quick Coupler	○	○
Boom Floating Control	○	○
Fine Swing Control	○	○
One Pedal Straight Travel System	○	○
Accumulator for Lowering Work Equipment	●	●
Pattern Change Valve (2 Patterns)	○	○
Semi-Auto Grease (Pump&Gun)	○	○
Removable Counterweight	○	○
Air Cleaner - Wet	○	○
Tool Kit	○	○

● : Standard
○ : Option

* Standard and optional equipment may vary. Contact your Hyundai dealer for more information.

The machine may vary according to International standards.

* The photos may include attachments and optional equipment that are not available in your area.

* Materials and specifications are subject to change without advance notice.

MEMO

MEMO

HYUNDAI

Specifications and design are subject to change without notice. Pictures of Hyundai Construction Equipment Europe products may show other than standard equipment.

Hyundai Construction Equipment Europe nv.
Hyundailaan 4, 3980 Tessenderlo, Belgium.
Tel: (32) 14-56-2200 Fax: (32) 14-59-3405

READY TO CHANGE YOUR WORLD?

Contact your Hyundai dealer.
hyundai-ce.eu/en/dealer-locator